

HEAT TORCH™

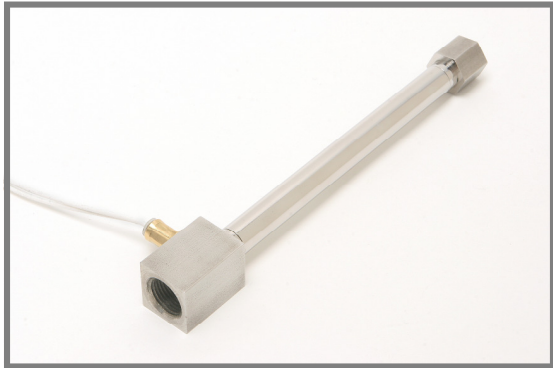

Shown with optional inlet & exhaust fittings

HT050

- This 0.5" diameter Heat Torch™ 050 In-line Heater is compact and reliable when moderate amounts of focused air are required.
- The Heat Torch™ 050 Air Heater has allowable air flow ranging from 1 to 10 SCFM and is available in power ratings of 100 watts to 500 watts (with standard increments of 50 watts). Maximum air input temperature is 250°F (121°C) with 1300°F (704°C) maximum output.
- Applications for Heat Torch™ 050 include staking, curing, drying, heat shrinking, sterilization, and adhesive activation.

| Airflow (SCFM) | Pressure Drop (psig) |
|----------------|----------------------|
| 1 | .53 |
| 2 | 2.1 |
| 3 | 4.7 |
| 4 | 8.4 |
| 5 | 13.2 |
| 6 | 19.0 |
| 7 | 25.8 |
| 8 | 33.7 |
| 9 | 42.7 |
| 10 | 52.7 |

| Wattage | Min. SCFM Req. |
|---------|----------------|
| 0.1kW | 1.0 |
| 0.2kW | 1.0 |
| 0.3kW | 1.0 |
| 0.4kW | 1.0 |
| 0.5kW | 1.0 |
| 0.6kW | 1.0 |

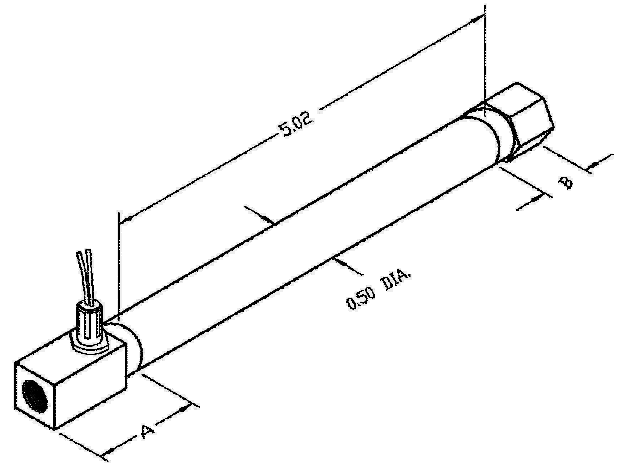

Wattage & Voltage Options

120V, single phase, 0.1kW-0.6kW
 208V, single phase, 0.2kW-0.55kW
 240V, single phase, 0.2kW-0.6kW

Other Options

Thermocouple Fitting
 Thermocouple
 Flexible Conduit

Fitting Options

Inlet Fitting:
 1/8F- 1/8" FNPT
 3/8F- 3/8" FNPT
 CB- Counterbore 1/2" O.D.

Exhaust Fitting:
 1/8F- 1/8" FNPT
 1/4F- 1/4" FNPT
 NF- No Fitting

| Inlet Fitting | Dim. A | Exhaust Fitting | Dim. B |
|---------------|--------|-----------------|--------|
| 1/8F | 1.32 | 1/8F | 0.54 |
| 3/8F | 1.45 | 1/4F | 0.85 |
| CB | 1.32 | NF | 0.04 |

Specifications

Category:

**Inline Heaters,
 Process Heaters,
 Open Coil Heaters**

Max. wattage: 0.6kW
 Max. exhaust air temp.: 1300°F
 Max. inlet air temp.: 250°F
 Max. SCFM: 10
 Max Allowable Pressure: 120 psig
 Mounting: Horizontal/Vertical
 Leads: 20 gauge (12" long)
 Heater Body: 304 Stainless Steel
 Inlet Fitting: 303/304 Stainless Steel
 Exhaust Fitting: 303/304 Stainless Steel



Part Number Key

